

A	B	C	D	E	F	G	H	L	J	K	L
							REV. 1-ALTER. SUPORTE - ALT-DM-0087/2008				
							REV. 2-ALTER. GEOMETRIA FLANGES DO TRANSMISSOR - ALT-DD-0016/2010				
							REV. 3-ALTER. TITULO E GEOM. FLANGES - ALT-0440/14				
							REV. 4-ACRESC NOTAS E TITULO EM INGLES - ALT-0821/2021				

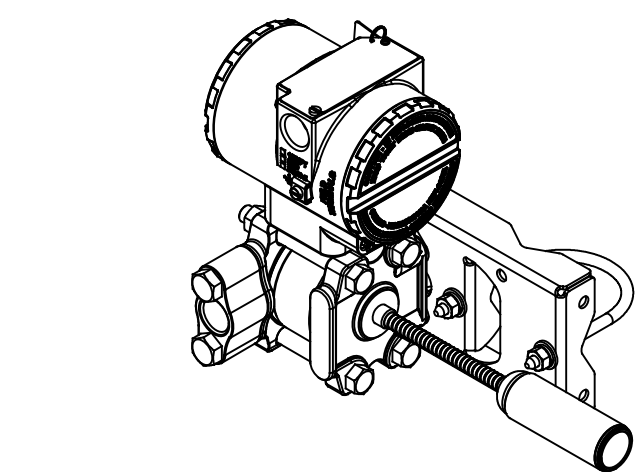
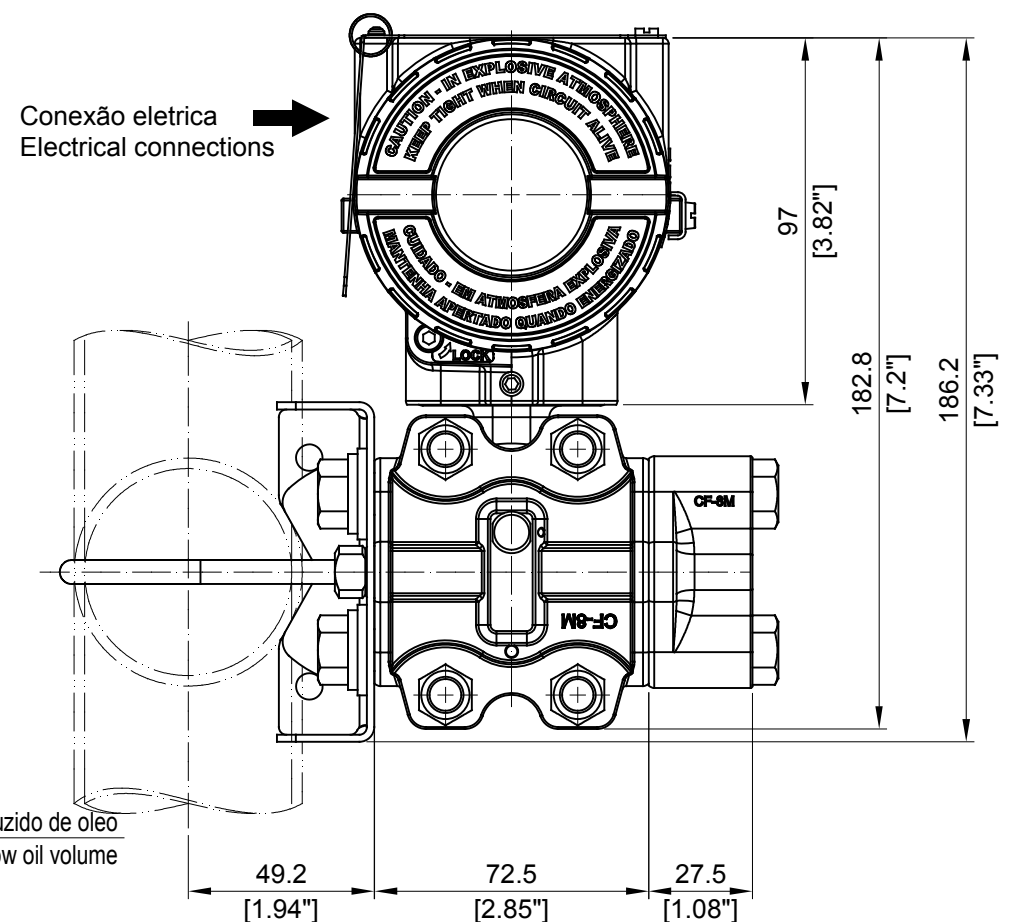
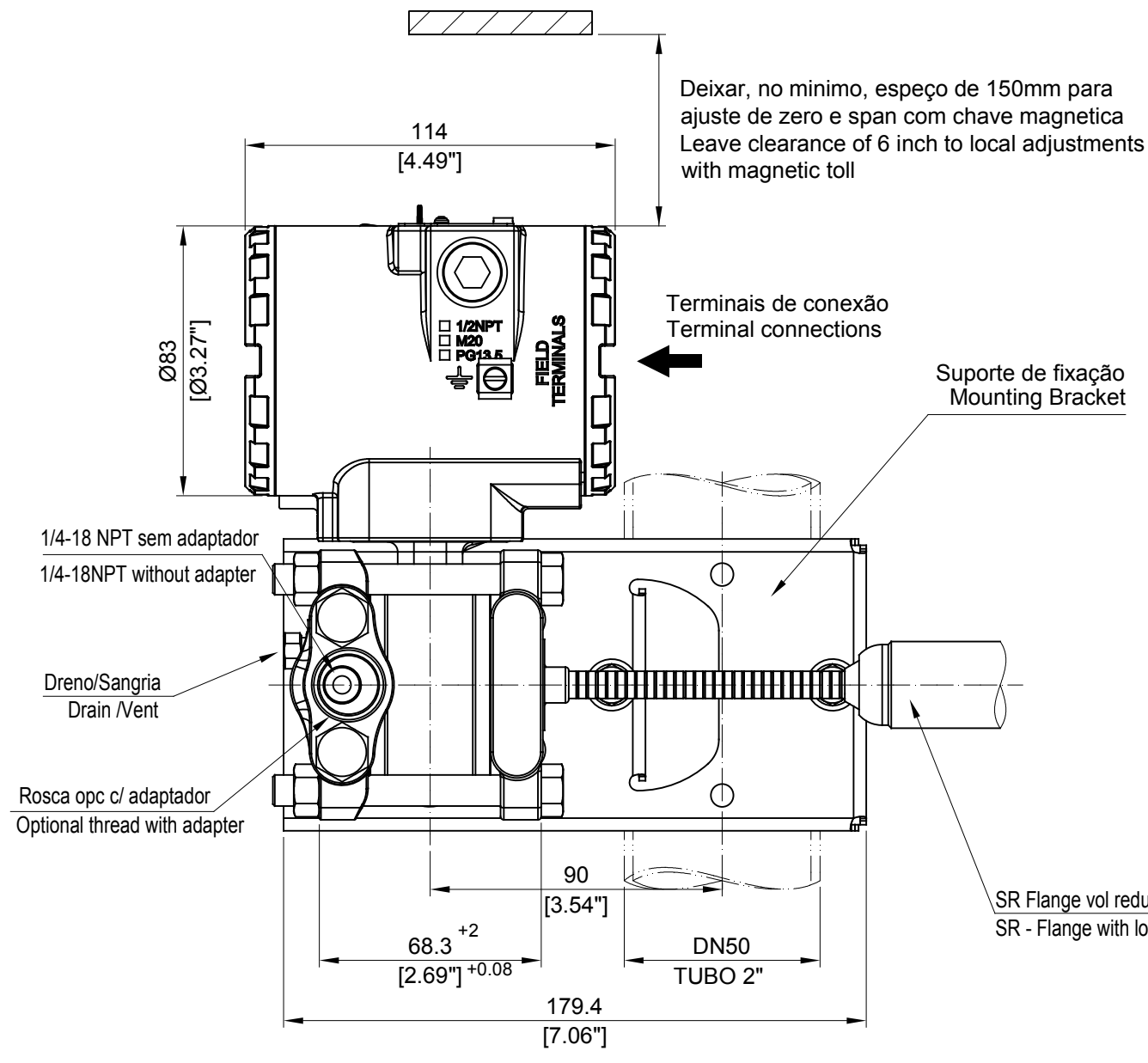

NOTAS/NOTES:
 AS DIMENSÕES SÃO EM mm (POLEGADAS)
 MONTAGEM LIMITADA A FLANGES CLASSE 600/PN100
 MONTAGEM CLASSES MAIORES QUE 600 USAR FLANGES REFORÇADOS
 DIMENSIONS ARE IN mm (INCH)
 ASSEMBLY LIMITED TO CLASS 600 / PN100
 HIGHER 600 CLASSES USE REINFORCED FLANGES

4	GUSKA 03 / 05 / 2021	P.MISAWA 03 / 05 / 2021	GERAL	DESENHO	PROJETO	VERIFIC.	APROVAÇÃO	smar
3	GUSKA 26 / 08 / 2014	P.MISAWA 11 / 03 / 2015	GERAL	EDNA	EDNA	GUSKA	P.MISAWA	
2	GUSKA 05 / 04 / 2010	P.MISAWA 05 / 04 / 2010	GERAL	CLIENTE				OS
1	GUSKA 25 / 08 / 2008	P.MISAWA 25 / 08 / 2008	GERAL	EQUIPAMENTO LD300 SERIES				DESENHO N°
REV	PROJETO	APROVAÇÃO	AREA	DIMENS. LD30XD ALTA SELO VR BAIXA 1/2NPT LD30XD HIGH REMOTE SEAL VR ; LOW 1/2NPT				101-B-5394-04
							ESC 1:2	FL /